

LT-PT2500AH-X

Powertrain Lift Table
(Air / Hydraulic Operation)
2,500 lbs. Capacity

The iDEAL LT-PT2500AH-X is a 2,500 lb. portable, high-rise industrial grade air-hydraulic lift table, incorporating a multi-adjustable powertrain platform primarily designed to assist with controlled lifting & lowering tasks to safely remove, replace or service heavy vehicle powertrain components such as engines, transmissions, drive-axle & transaxle assemblies, or other similar heavy components. The LT-PT2500AH-X comes standardly equipped with a durable multi-adjustable powertrain platform that includes extendable length, tilt & height adjustments, while also incorporating an exclusive fully operational pneumatic hand operated 'stainless-steel' control panel with integrated air gauge & water separator. In addition, iDEAL Powertrain 2500 lb. Lift Table comes standard with high-quality locking swivel & directional poly casters, tool tray, removable hand bar, double scissor design, HD air-hydraulic pump & hydraulic cylinder, tie-down anchors, and heavy duty ratchet strap all combined to provide maximum strength, stability, and safety for added efficiency and convenience. Optional 'quick mount' PT Support Stand Kit also available, providing additional support for various powertrain components.

Features

- 2,500 LBS CAPACITY
- INNOVATIVE, HIGH QUALITY PORTABLE SCISSOR LIFT DESIGN
- EFFICIENT & SAFE METHOD TO INSTALL OR REMOVE HEAVY VEHICLE POWERTRAIN COMPONENTS IE: TRANSMISSIONS, ENGINES OR AXLES
- FULL OPERATION AIR SYSTEM HAND CONTROLS FOR LIFTING, LOCKING & LOWERING
- COMPRESSED AIR / HP HYDRAULIC OPERATION (90 TO 125 PSI)
- INTEGRATED AIR GAUGE W/ WATER SEPARATOR
- HD PT 'EXTENDABLE & SLOTTED' PLATFORM W/ 5.2" ADJUSTMENT LENGTH
- HD JACK SCREWS FOR PRECISION 'TILT & HEIGHT' PLATFORM ADJUSTMENTS
- DOUBLE SCISSOR HD DESIGN W/ HQ HYDRAULIC CYLINDER
- INTEGRATED UTILITY / TOOL TRAY & SUB-PLATFORM STORAGE AREA
- DURABLE 'DIRECTIONAL & LOCKING' POLY SWIVEL CASTERS
- PT PLATFORM SIZE 23.6"W X 31.5 - 36.7"L
- 3EA LOCKING HEIGHT POSITIONS
- MAX PT PLATFORM HEIGHT 72"
- MIN PT PLATFORM HEIGHT 35"
- OVERALL SIZE 71.3"L X 33.5"W
- 72S RISE & 33S LOWER TIME
- INCLUDES 4EA TIE-DOWN RING EYELETS & HD RATCHET STRAP
- DURABLE POWDER-COAT FINISH



Specifications

Lift Model	LT-PT2500AH-X
Capacity	2,500 lbs.
Overall Length	71.3"
Overall Width	33.5"
Max PT Platform Height	72"
Min PT Platform Height	35"
Hand Bar Height	39.2"
PT Platform Adj. Size (L x W)	31.5" to 36.7" x 23.6"
PT Platform Adj. Tilt Angle (+/-)	6° to 8°
PT Platform Locking Heights	49", 61", 68"
Lifting / Lowering Rate	72S / 33S
Power Supply (Compressed Air)	90 - 125 PSI (6 - 9 Bar)
Ship Weight	798 lbs.

Optional Kit Accessory

LT-PT-PSAEK
PT PLATFORM, SUPPORT ADAPTORS
& EXTENSION KIT



- PROVIDES ADDITIONAL PT PLATFORM SUPPORT FOR DIFFER POWERTRAIN COMPONENTS
- QUICKLY MOUNTS TO SLOTS ON PT PLATFORM
- INCLUDES 4EA (1"D X 8"H) SUPPORT STANDS W/ M10 FLANGE BOLT & NUT MOUNT HARDWARE
- INCLUDES 4EA SHORT (5"H) & 4EA LONG (9"H) HEIGHT EXTENSIONS FOR 19.75" MAX HT.
- DURABLE ZINC PLATED STANDS & EXTENSIONS



Premium Products at Affordable Prices!!



LT-PT2500AH-X

More Features, More Value!!

HIGH-RISE, POWERTRAIN 'AIR-HYDRAULIC' LIFT TABLE 2.500 LB. CAPACITY

'MULTI-ADJUSTABLE' PT POWERTRAIN PLATFORM

FULLY OPERATIONAL HAND CONTROLS FOR LIFTING, LOCKING & LOWERING

HD RATCHET STRAP

SUB-PLATFORM STORAGE AREA

POLY 'DIRECTIONAL & LOCKING' SWIVEL CASTERS

MAX HT 72"
MIN HT 35"

'INLET' AIR FITTING
'STAINLESS-STEEL' CONTROL PANEL W/ AIR GAUGE & WATER SEPARATOR

REMOVABLE HANDLE

GREASE ZERKS

AIR SYSTEM SAFETY LATCHES

UTILITY / TOOL TRAY

HD DOUBLE SCISSORS W/ HQ HYDRAULIC CYLINDER

(FRONT) DIRECTIONAL & SWIVEL LOCK

(BACK) SWIVEL LOCK

HQ AIR / HYDRAULIC POWER UNIT (90 - 125 PSI OP)



'PT' POWERTRAIN 'MULTI-ADJUSTABLE' PLATFORM FEATURES & SPECS

PT PLATFORM EXTENDS BY 5.2"

THREADED 'TOP OR SIDE' TIE-DOWN EYELET ANCHORING POSITIONS

QUICK 'HAND ADJUST' HD JACK SCREWS FOR PRECISION 'TILT & HEIGHT' ADJUSTMENTS

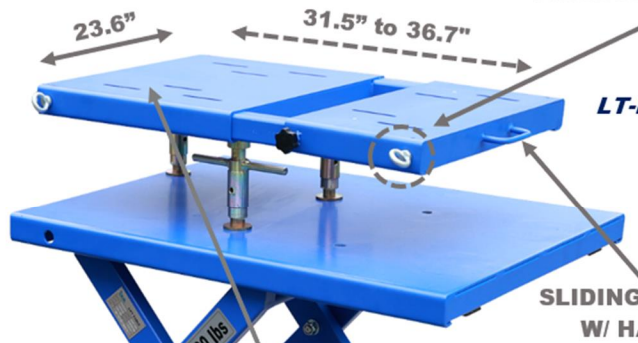

LT-PT2500AH-X

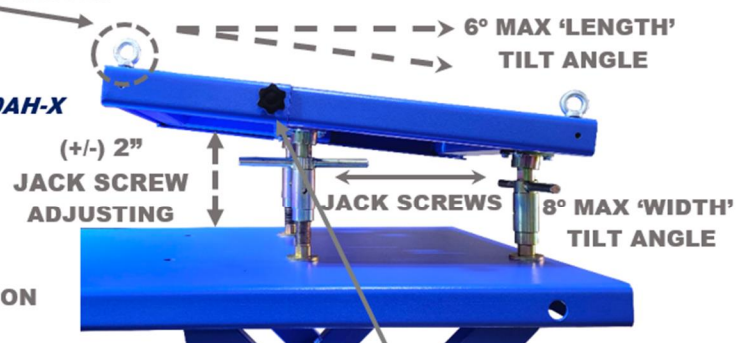

'SLOTTED' PT PLATFORM FOR OPTIONAL 'QUICK MOUNT' PT SUPPORT STAND KIT

'THREADED' KNOB SCREWS TO SECURE SLIDING PLATFORM

Premium Products at Affordable Prices!!

www.idealautoequip.com

www.tuxedoautoequip.com



IDEAL LT-PT2500AH-X (FEB 2024)